

BEGANE GROND.  
BESTAAND.

VERDIEPINGSVLOER  
BESTAAND.

VERDIEPINGSBALKLAAG  
BESTAAND.

KAPPLAN  
BESTAAND.

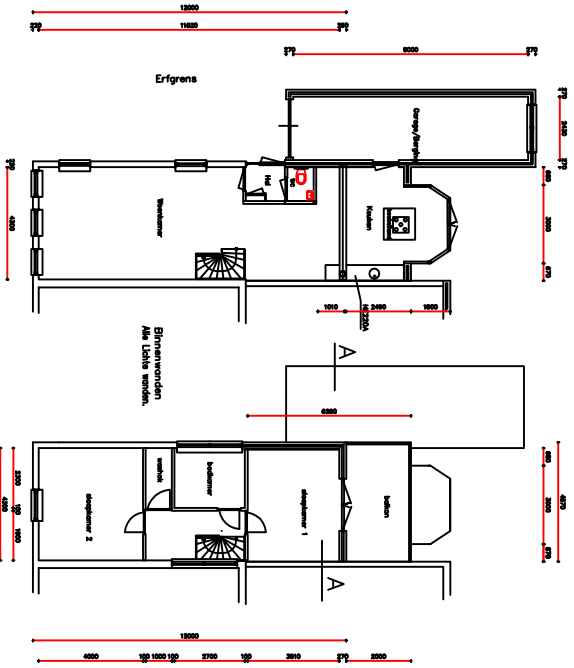

BEGANE GROND.  
GEWIJZIGD.

VERDIEPINGSVLOER  
GEWIJZIGD.

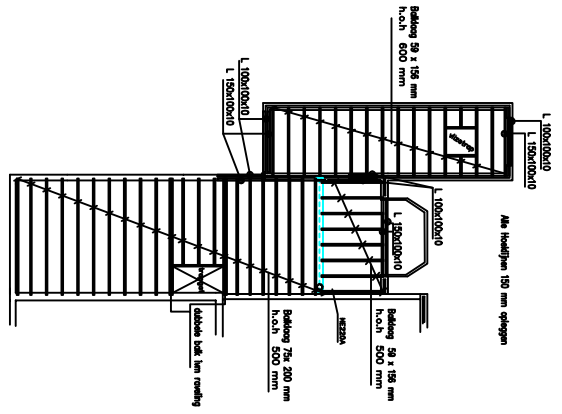

VERDIEPINGSBALKLAAG  
GEWIJZIGD.

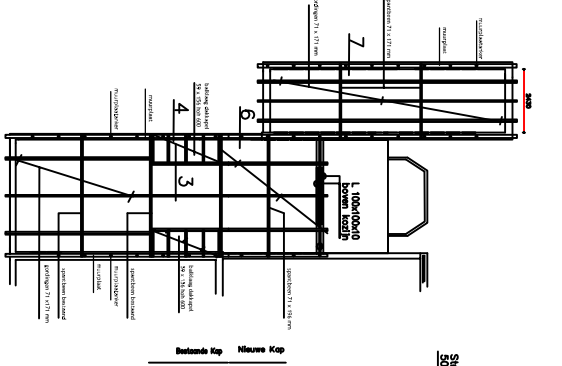

KAPPLAN  
GEWIJZIGD.

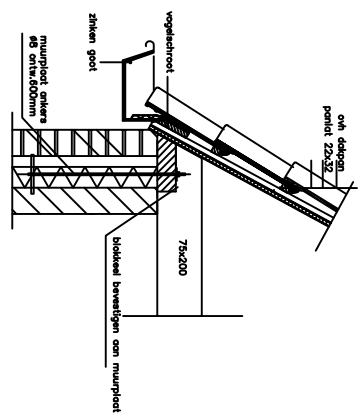

DETAIL 6

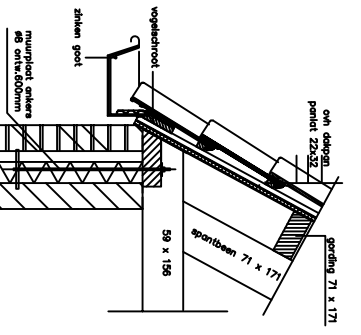

DETAIL 7

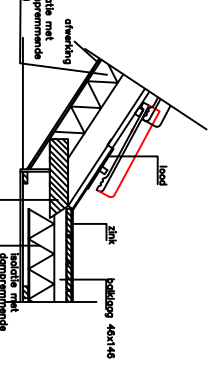

DETAIL 3

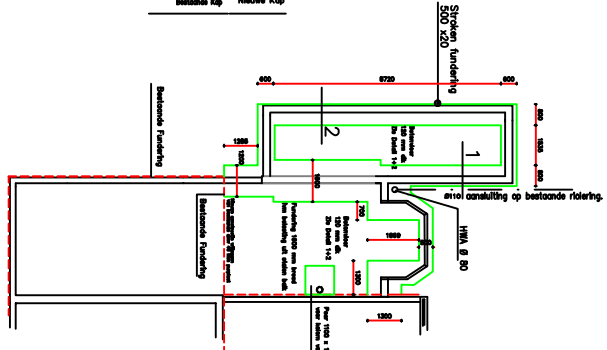

DETAIL 1

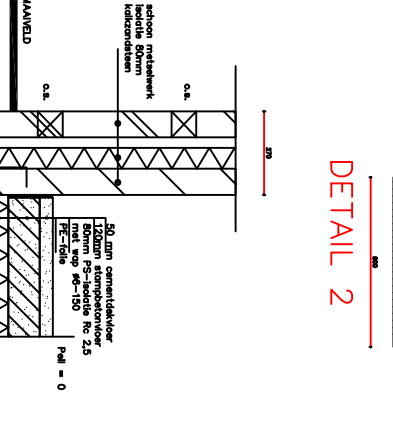

DETAIL 2

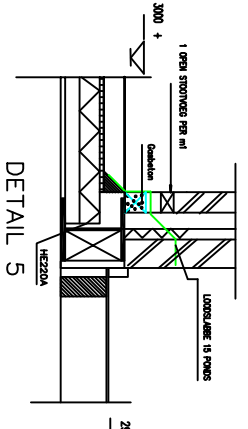

DETAIL 4

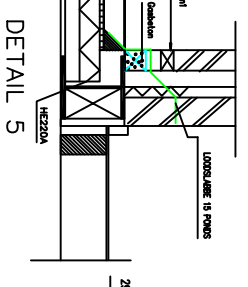

DETAIL 5

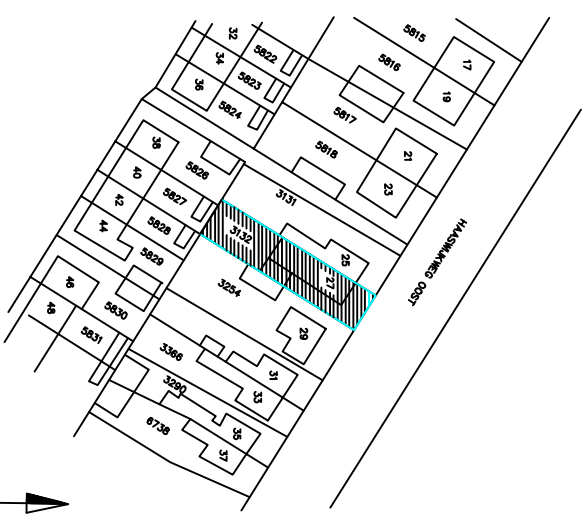

situatie:  
Kadastrale gemeente : Dordrecht  
Sectie : I  
Perceelnummer : 3153  
Hoofdwijkweg Oost 27  
3319 GA Dordrecht  
Schaal: 1 : 500

**BESTEKTEKENING**

ontwerper	Form. R. Smid Post 27 3319 GA Dordrecht Uitbreiding Woning Hoozwijkweg 27 3319 GA Dordrecht	schaal	1:100 / 1:10	teken	01
aanvrager	ANDEUR/BAUW De Oever 4 3319 GA Dordrecht www.janheijmansbouw.nl KVK Brno: 10087234	datum	24-01-2028	teken	01
titel	0806	teken	01	teken	01